

SOFAR

# USER MANUAL

GTX5000S

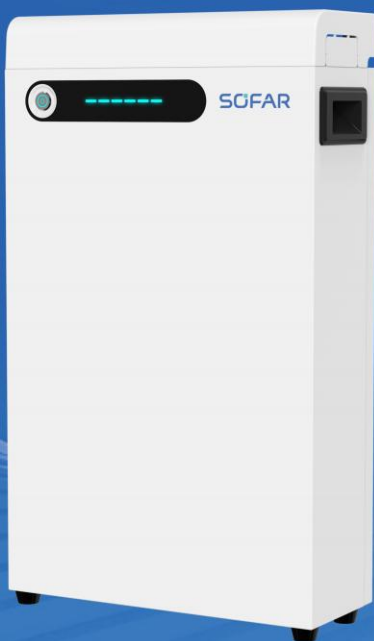

**Guangdong SOFAR Smart Solar Technology Co., Ltd.**

No.1, Dongsheng North Road, Chenjiang Street,  
Zhongkai High-tech Zone, Huizhou City,China

Email: [service@SOFAR.com](mailto:service@SOFAR.com)

Web: [www.sofarsolar.com](http://www.sofarsolar.com)

EU Representative Information: SofarSolar GmbH

Add.: Kraemerstrasse 20, 72764 Reutlingen, Germany

Tel: +49 (0)7121 31767-0

Email: [europa@sofarsolar.com](mailto:europa@sofarsolar.com)

Document number

Issue 1 | 8. 2025

English

# CONTENT

<b>Preface</b>	<b>1</b>
<b>1 General information</b>	<b>3</b>
1.1 Validity	3
1.2 Intended use	3
1.3 Identifying the product	4
<b>2 Safety</b>	<b>5</b>
<b>3 Technical Items</b>	<b>7</b>
<b>4 Product Overview</b>	<b>8</b>
4.1 Brief Introduction	8
4.2 Interface Introduction (Front Side)	9
4.3 Interface Introduction	12
<b>5 Installation Guide</b>	<b>18</b>
5.1 Checking Before Installation	18
5.2 Tools	22
5.3 Installation requirements	23
5.4 Installation instructions	23
5.5 Electrical Connection	26
<b>6 Cleaning and Maintenance</b>	<b>30</b>
6.1 Cleaning	30
6.2 Maintenance	30
<b>7 DataSheet</b>	<b>33</b>

## Preface

### Notice

The purchased products, services and features are governed by the commercial contract made by the Company. All or part of the products and features described in this document may not be within the purchase scope. Except as otherwise agreed herein, no representations or warranties, express or implied, are made as to the contents of this document.

### Save this instruction

This manual must be considered as an integral part of the equipment. Customer can print the electronic version to hard copy and keeping properly for future reference. Anyone who operates the device at any time must operate in accordance with the requirements of this manual.

### Copyright declaration

The copyright of this manual is owned by SOFAR. It may not be copied – neither partially nor completely – by companies or individuals (including software, etc.) and must not be reproduced or distributed in any form, or with the appropriate means.

SOFAR reserves the right to final interpretation. This manual may be amended following feedback from users or customers.

Consult our website at: <https://www.SOFAR.com> for the latest version.

### Symbols used

This manual provides safety operation information and uses the symbol in order to ensure personal and property security and use inverter efficiently when operating the inverter. You must understand these emphasized information to avoid the personal injury and property loss. Please read the following symbols used in this manual carefully.

 **DANGER**

- ▶ Danger indicates a hazardous situation which, if not avoided, will result in death or serious injury.

 **WARNING**

- ▶ Warning indicates a hazardous situation which, if not avoided, could result in death or serious injury.

 **CAUTION**

- ▶ Caution indicates a hazardous situation which, if not avoided, could result in minor or moderate injury.

**NOTICE**

- ▶ Attention indicates potential risks which, if not avoided, may lead to equipment fault or property damage.

- ▶ Note provides tips that are valuable for the optimal operation of the product.

# 1 General information

This manual introduces GTX5000S LFP Battery Product from SOFAR. Please read this manual before you use the battery. Any confusion, please contact SOFAR immediately for advice and clarification.

## 1.1 Validity

This user manual is applicable to SOFAR GTX5000S.

This user manual contains SOFAR GTX5000S product information, usage guidance, safety information, installation guide and details on common operating issues and subsequent corrective actions.

## 1.2 Intended use

SOFAR GTX5000S is an energy storage unit that is designed to be used in residential on/off grid applications with the capability for short-term backup.

Notes regarding intended use:

SOFAR GTX5000S is not suitable for supporting life-sustaining medical devices. This product is intended for use only in accordance with the information provided in the enclosed documentation and with the locally applicable standards and regulations. Any other application may cause personal injury or property damage.

The illustrations in this manual are meant only to help explain system configuration concepts, includes usage guidance, safety precautions, and common operating issues and subsequent corrective actions.

Alterations to the product, e. g. changes or modifications, are only permitted with the express written permission of SOFAR. Unauthorized alterations will void warranty claims. SOFAR shall not be held liable for any damage caused by such changes. Any use of the product other than that described in the Intended Use section does not qualify as appropriate. The enclosed documentation is an integral part of this product. Keep the documentation in

a convenient place for future reference and observe all instructions contained therein. The type label (see Section 1.3) must remain attached to the product. Please contact SOFAR or local after-service providers within 1 week once the user decides to cease using their SOFAR Battery products.

### 1.3 Identifying the product

The type labels were attached on the product, which contain the product identification information. For safe usage, the user must be well-informed of the contents in the type labels.

The type labels include:

<p><b>SOFAR</b> <i>Rechargeable Li-ion Battery</i></p> <p>IFpP/51/161/120/[1P16S]M/-20+60/90</p> <p><b>Model:</b> GTX5000S</p> <p>Ratings: 5120Wh/51.2V/100Ah</p> <p>Charge Voltage: 57.76V</p> <p>Max. Output Power: 2.7KW</p> <p>IP Rating: IP65</p> <p>Guangdong Sofar Smart Solar Technology Co., Ltd. No. 1 Dongsheng North Road, Chenjiang Street, Zhongkai High-tech Zone, Huizhou City (One license multiple addresses)</p> <p><b>CAUTION !</b></p> <ul style="list-style-type: none"> <li>Do not disassemble</li> <li>Do not short-circuit</li> <li>Do not place in fire or near hot source</li> <li>Please read user manual carefully</li> </ul> <p>IEC 62619 UN 38.3</p> <p>Made in China</p>	<p><b>DANGER !</b> CHEMICAL HAZARD &amp; SHOCK HAZARD</p> <ul style="list-style-type: none"> <li>Do not disassemble or repair by yourself.</li> <li>Do not drop, deform, impact, cut or spearing with a sharp object.</li> <li>Do not place near open flame or incinerate.</li> <li>Do not put any objects onto the battery.</li> <li>Do not allow to contact with liquid.</li> <li>Keep out of reach of children, animals or insects.</li> <li>Contact the supplier within 24 hours if anything wrong.</li> </ul> <p><b>WARNING !</b></p> <p>Stop the battery operation immediately to secure the battery safety when environmental temperature is over working temperature (suitable operation temperature is 0-45°C). If battery is at high temperature usually, it will impact battery performance.</p>
--	---

## 2 Safety

This section contains safety information that must be observed at all times when working on or with batteries. To prevent personal injury or property damage and to ensure long-term operation of the batteries, read this section carefully and observe all safety information at all times.

### WARNING

#### Environmental requirement

- ▶ Do not expose the battery to temperature above 50°C
- ▶ Do not place the battery near any heat sources
- ▶ Do not expose the battery to moisture or liquids
- ▶ Do not expose the battery to corrosive gases or liquids
- ▶ Do not expose the battery to direct sunlight for extended periods of time
- ▶ Do not allow the battery power terminals to touch conductive objects such as wires
- ▶ Place battery in secure location away from children and animals

### WARNING

#### Operation precautions

- ▶ Do not disassemble the battery
- ▶ Do not touch the battery pack with wet hands
- ▶ Do not crush, drop or puncture the battery
- ▶ Do not reverse the polarity or connect in series
- ▶ Do not short circuit the terminals, remove all jewelry items that could product a short circuit before installation and handling
- ▶ Always dispose of the product according to local safety regulations
- ▶ Store and recharge battery in a manner in accordance with this user manual

- ▶ .Ensure reliable grounding
- ▶ .Disconnect battery from power/load and then power off battery before installation and maintenance
- ▶ .When storing or handing, do not stack up batteries when outside

 **WARNING**

**Protective package**

- ▶ Packaged batteries should not be stacked more than specified number stipulated on the package
- ▶ Continued operation of a damaged battery can result in dangerous situation that may cause severe injury due to electrical shock

### 3 Technical Items

No.	Terms	Comment
1	Discharge	Battery output power for load
2	Charge	To put electricity into battery by charger
3	Full charge	Battery had been full charged, SOC is 100%.
4	Standby	Ready for charging or discharging
5	Shutdown	Power off
6	SOC	State of Charge (Useable capacity)
7	Battery voltage	The voltage between B+/B-
8	Cell voltage	Single cell voltage
9	Pack voltage	The voltage between P+/P-
10	Alarm	Indicate that the battery is in abnormal status
11	Protect	Battery stops charging or discharging and is recoverable
12	Fault	Battery or BMS is broken, need to be replaced
13	Over discharged	Battery is lack of electricity, and needs to be recharged in time

## 4 Product Overview

### 4.1 Brief Introduction

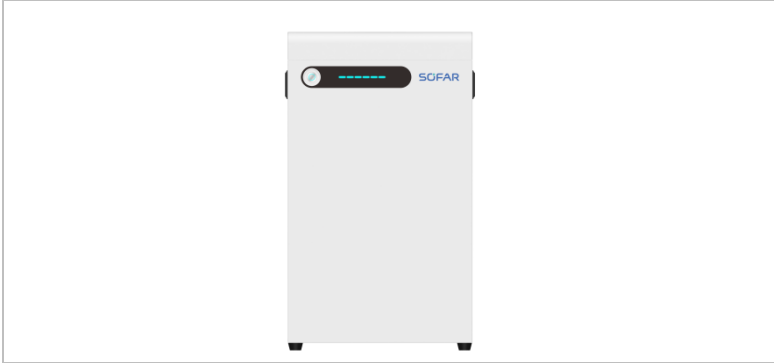

#### **Product overview**

SOFAR GTX5000S is a battery system with an operating voltage range between 44.8~57.6V. It is utilized in household energy storage applications and works together with a low-voltage PCS to realize the goal of energy storage for the home.

SOFAR GTX5000S has built-in BMS (battery management system), which can manage and monitor cells information including voltage, current and temperature. What's more, BMS can balance cells charging to extend cycle life. BMS has protection functions including over-discharge, over-charge, over-current and high/low temperature; the system can automatically manage charge state, discharge state and balance state.

Multiple batteries can connect in parallel to expand capacity and power for larger capacity and longer power supporting duration requirements, SOFAR GTX5000S support up to 4 parallel operations.

## 4.2 Interface Introduction (Front Side)

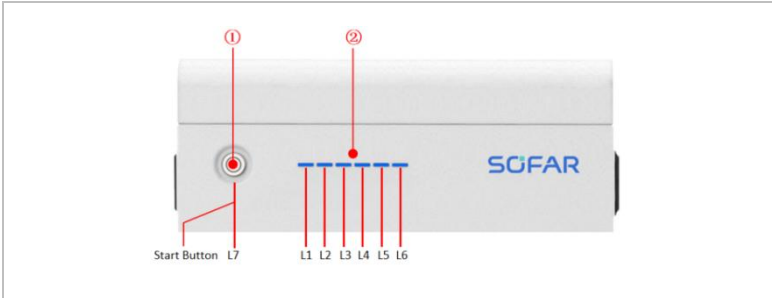

No.	Items
1	Start Button Status Indicators
2	Battery Level Indicator

### 4.2.1 Start Button

Start button integrated LED status Indicators, to show battery running status or warning status.

1. Press start button more than 3s and then release the button, LED will light from L7 to L1, and then enters to automatic coding, all LED lights flash and L7 is shown as purple. After the automatic coding, L1 to L6 shows the normal capacity, and L7 shows the running status:
2. Blue, long lighting when charging and flash when discharging;
3. Red, long bright if equipment failure or protected.
4. In parallel system, connect the parallel communication wiring according to section 4. 3. 1, then long press the start button of the Master PACK, after normal startup, the battery system will automatically encode and assign ID to each parallel PACK, and then the parallel system will run normally.
5. Press start button of Master PACK more than 3s and then release the button, LED will lights from L1 to L7 to shut down the battery module. In parallel system, the master pack will shut down after all slave packs shut down.

### 4.2.2 LED Indicator Definition

- ▶ L1 to L6: Blue, show the battery level, each light indicates 16.67% SOC.
- ▶ L7: Blue or Red, show battery running status, blue is normal, red is abnormal.

Table 4-1 LED indicator instructions

		RUN	ALM	Battery level indicator							
Status	L7		L6	L5	L4	L3	L2	L1	Descriptions		
Shutdown		OFF	OFF	OFF	OFF	OFF	OFF	OFF	OFF	All OFF	
Standby		Flash 1	OFF	According to the battery level						Indicates Standby	
Charging	Normal	Light	OFF	According to the battery level						The highest capacity indicator LED flashes (flash 2), others lighting	
	Full Charged	Light	OFF	Light	Light	Light	Light	Light	Light	Turn to standby status when charger off	
	Protection	OFF	Light	OFF	OFF	OFF	OFF	OFF	OFF	Stop charging	
Discharging	Normal	Flash 3	OFF	According to the battery level							
	UVP	OFF	OFF	OFF	OFF	OFF	OFF	OFF	OFF	Stop discharging	
	Protection	OFF	Light	OFF	OFF	OFF	OFF	OFF	OFF	Stop discharging	
Fault		OFF	Light	OFF	OFF	OFF	OFF	OFF	OFF	Stop charging and discharging	

Table 4-2 Charging battery level indicators instructions















Status			Charging					
Battery level indicators		L7 	L6 	L5 	L4 	L3 	L2 	L1 
Battery level (%)	0~17%	Light	OFF	OFF	OFF	OFF	OFF	Flash 2
	18~33%		OFF	OFF	OFF	OFF	Flash 2	Light
	34~50%		OFF	OFF	OFF	Flash 2	Light	Light
	51~66%		OFF	OFF	Flash 2	Light	Light	Light
	67~83%		OFF	Flash 2	Light	Light	Light	Light
	84~100%		Flash 2	Light	Light	Light	Light	Light

Table 4-3 Discharging Battery Level Indicators Instructions

Status			Discharging					
Battery level indicators		L7 	L6 	L5 	L4 	L3 	L2 	L1 
Battery level (%)	0~17%	Flash 3	OFF	OFF	OFF	OFF	OFF	Light
	18~33%		OFF	OFF	OFF	OFF	Light	Light
	34~50%		OFF	OFF	OFF	Light	Light	Light
	51~66%		OFF	OFF	Light	Light	Light	Light
	67~83%		OFF	Light	Light	Light	Light	Light
	84~100%		Light	Light	Light	Light	Light	Light

**The flashing instructions**

- ▶ flash 1 - light 0. 25s / off 3. 75 seconds
- ▶ flash 2 - 0. 5s light / 0. 5s off
- ▶ flash 3 - 0. 5s light / 1. 5s off

### 4.3 Interface Introduction

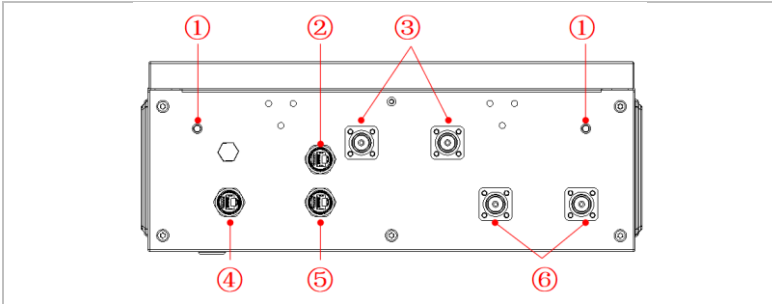

No.	Items	No.	Items
1	Grounding	4	Reserved
2	CAN/Link In	5	Link Out
3	P-	6	P+

#### 4.3.1 Wiring instructions

Applicable to CEC requirements in Australia only.

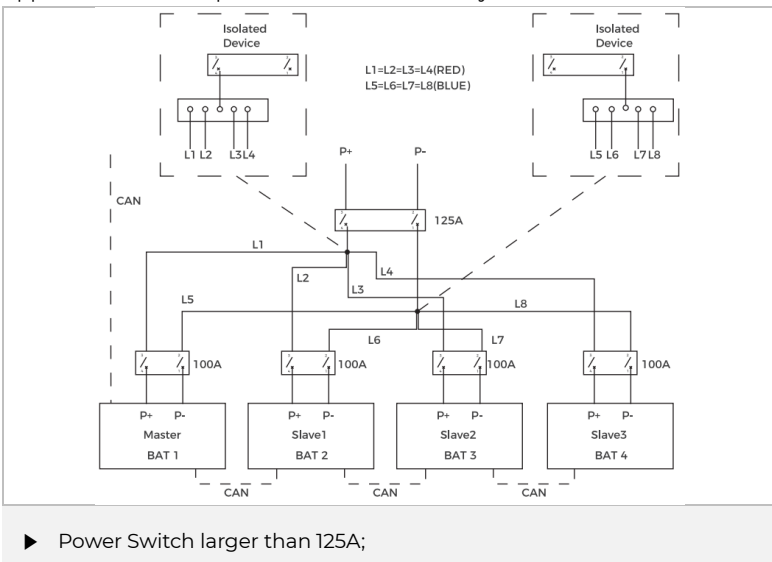

- ▶ You are advised to use the EV power cable with size min. 25 mm<sup>2</sup> or 3AWG (600V, 125A) and length min. 1500mm. The length of the power cable from connector terminals of each battery pack to the battery connector interface of PCS should be same by isolated device.
- ▶ Before assembling Power cable, label the cable polarities correctly to ensure correct cable connections.
- ▶ The power cable installation and connected must training skilled of professional personal.

Suggest Wiring Diagram (except CEC):

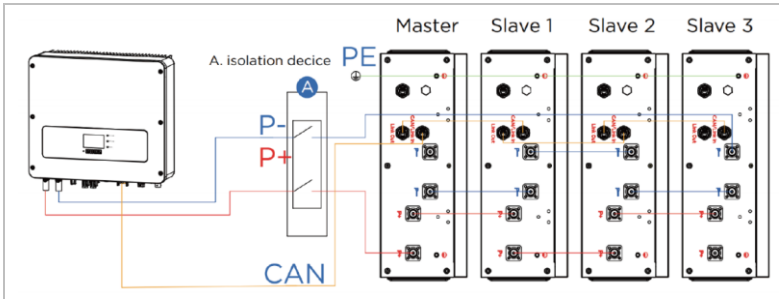

### 1. Power cable wiring instructions

**Power cable terminals:** There are two pair of power terminals, each pair with same function.

**Single module:** Any of the terminals of each pair can be used.

**Parallel system:** Multiple batteries can connect in parallel to expand capacity and power for larger capacity and longer power supporting duration requirements.

- ▶ P+ must connect to master pack, and P- must connect to last slave pack.

**Master pack:** one of the P+ terminals connect to PCS, the other one paralleling to another battery for capacity expanding.

**Last slave pack:** one of the P- terminals connect to equipment, the other one paralleling to another battery for capacity expanding.

**Other slave pack:** for each pair terminals, paralleling to another battery for capacity expanding.

## 2. Parallel communication cable wiring instructions

CAN/Link In and Link Out communication terminal (RJ45 port) is integrated with the signal for automatic coding function, it's can automatic identification the parallel connected slave batteries by internal control software of master battery.

- ▶ The connection order of Port In and Port Out should not be wrong, otherwise it will lead to the automatic coding failed.

It is required that the CAN/Link In of the master PACK should be connected to the PCS, and the parallel communication wire is connected to the CAN/Link In of the first slave PACK from the Link Out of the master PACK. Then the Link Out of the first slave PACK is connected to the CAN/Link In of the second slave PACK. The Link Out of the second slave PACK is then connected to the CAN/Link In of the third slave PACK. The parallel system support up to 4 parallel operation, and Link Out of the last slave PACK do not connected to the communication line.

## 3. PCS communication cable wiring instructions

The CAN/Link In communication port of the Master pack is connected to PCS.

### NOTE:

- ▶ When using the inverter model ME 3000SP/HYD 3-6K-ES, this material number (101060300430-0) communication cable is required for the communication cable. The wiring port is shown in the figure. The communication cable is 8pin RJ45 to 4pin RJ11, the 4pin RJ11 needs to be connected to the CAN/485 port of the inverter, while the 8pin RJ45 needs to be connected to the CAN/Link In of the GTX5000S.

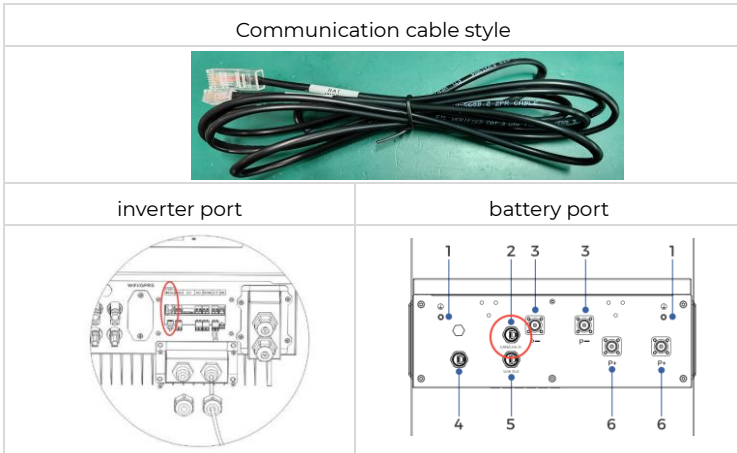

▶ When using the inverter model HYD-EP, a communication cable with the following part number (021.00000270-0) is required. The wiring port is shown in the figure. The communication cable is an 8pin RJ45 to two pin cable, Two of the pin cables are connected to the inverter COM port 1 and 2 (blue to 1, blue-white to 2), and the 8pin RJ45 is connected to the CAN/Link In of the GTX5000S.

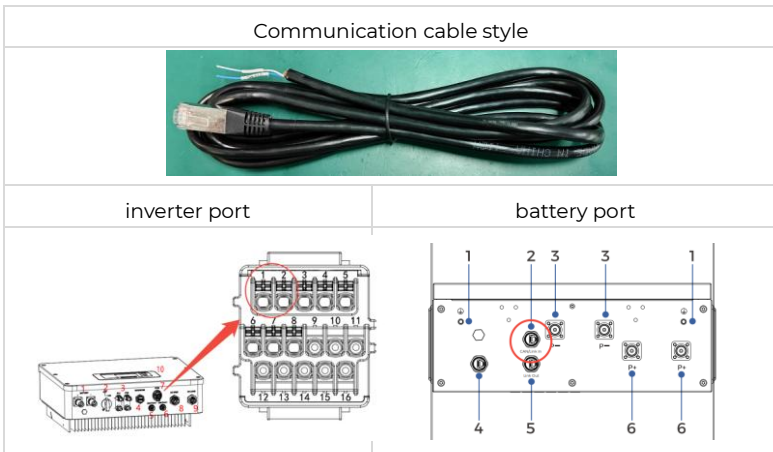

**4. Grounding wiring instructions**

The ground wire of the battery system needs to be connected reliably. Connect the grounding of the parallel system first, and then ground it nearby through the connection point of one of the battery packs.

### 4.3.2 Link Port and Automatic Coding Function

CAN/Link In and Link Out Communication follow CAN protocol, for communication between multiple parallel batteries.

After confirming the wiring is correct (refer to section 4.3.1), press the startup button of the master pack long.

After normal startup, the parallel battery system will automatically code and assign ID to each parallel PACK, and then the parallel system will run normally (refer to section 4.2.1).

### 4.3.3 Link Port

CAN Communication Terminal (RJ45 port) follow CAN protocol, connect to communication port.

BMS controls the charging current/charging voltage or discharge current/discharge cut-off voltage of the PCS through CAN communication according to the battery voltage and battery temperature.

► Through the SOFAR PCS, skilled peoples can set the fully charged time period.

PIN	Definition
Pin 1	NC
Pin 2	NC
Pin 3	CANH (to battery)
Pin 4	CANH (to PCS)
Pin 5	CANL (to PCS)

Pin 6	CANL (to battery)
Pin 7	GND/ID_OP-
Pin 8	ID_IN+/ID_OP+

#### 4.3.4 RS232 Port

RS232 Communication Terminal (RJ45 port) follow RS232 protocol, for manufacturer or professional engineer to debug or service.

PIN	Definition
Pin 7、Pin 1	GND
Pin 5	RS232_RX
Pin 6	RS232_TX
Pin2、Pin 3、Pin 4	NC

#### 4.3.5 Software version requirements

When the GTX5000S is used in conjunction with inverters of different models, there are requirements for the software versions of the inverter and the battery. The specific version requirements are as follows (this table may be updated in subsequent software optimizations):

Battery	software version	Inverter	software version
GTX5000S	V010062	ME3000	V3.60
	/	HYD-ES	V3.90
	/	HYD-EP	V070004

► The software versions marked in the table are all the minimum version requirements for the equipment. You can contact the local seller or SOFAR to upgrade the equipment to the latest standard version.

## 5 Installation Guide

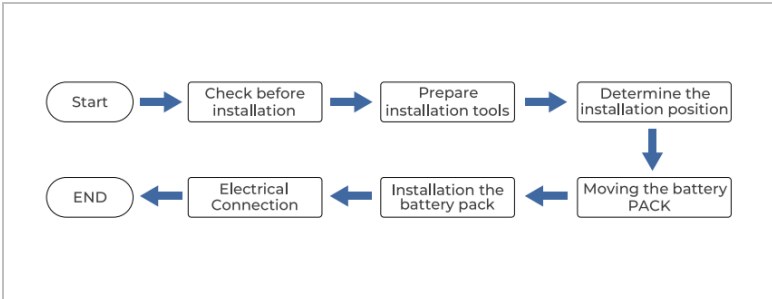

Table 5-1 Installation flow chart

### 5.1 Checking Before Installation

#### 5.1.1 Checking Outer Packing Materials

Packing materials and components may be damaged during transportation. Therefore, check the outer packing materials before installing the battery. Checking the surface of packing materials for damage, such as holes and cracks. If any damage is found, do not unpack the battery and contact the dealer as soon as possible. You are advised to remove the packing materials within 24 hours before installing the battery.

#### 5.1.2 Checking Deliverables

After unpacking the battery, check whether deliverables are intact and complete. If any damage is found or any component is missed, contact the dealer.

The below table shows the components and mechanical parts that should be delivered.

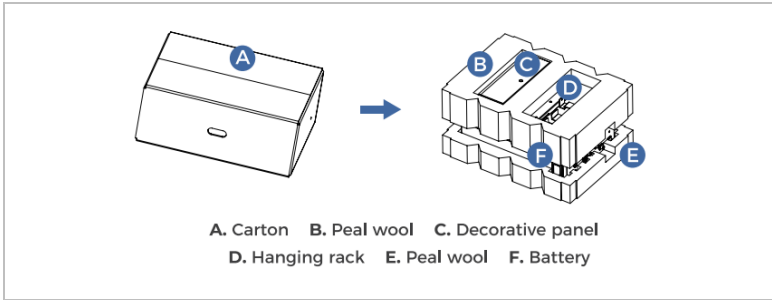

NO.	Pictures	Quantity	Description
1		1 pcs	Battery
2		2 pcs	Hanging rack1
3		1 pcs	Hanging rack2
4		1 pcs	Hanging rack3
5		9 pcs	M5*12
6		2 pcs	M6*14
7		4 pcs	M5*80
8		1 pcs	Decorative panel
9		1 pcs	Quick installation guide
10		1 pcs	Test report

The following accessories are configured according to the number of parallel machines in the battery system. For example:

NO.	Pictures	Quantity	Description
1	Master P+ to Slave P+ 	N-1 <sup>④⑤</sup> *	Parallel connections cable(P+)
2	Master P- to Slave P- 	N-1 <sup>④⑤</sup> *	Parallel connections cable(P-)
3	Master out to Slave in 	N-1 <sup>④⑤</sup> *	Parallel communication cable
4	Power cable (+) 	1 pcs	Output power cable(P+)
5	Power cable (-) 	1 pcs	Output power cable(P-)
6	Master CAN to inverter communication port 	1 pcs	Output communication cable

- ▶ The standard output power cable is optional accessories component part, the customer can be according the actual installation requirements customize the output power cable from SOFAR when the product sold in local or importers provide.
- ▶ <sup>④⑤</sup>\* N is indicating the parallel connections number of battery. The number of power cable and Communication cable is optional accessories according the parallel connection demand for customer.
- ▶ You are advising use the provide standard accessories part from SOFAR or customize the identical specification accessories component part from SOFAR or importers.

Power cable terminal making instructions:

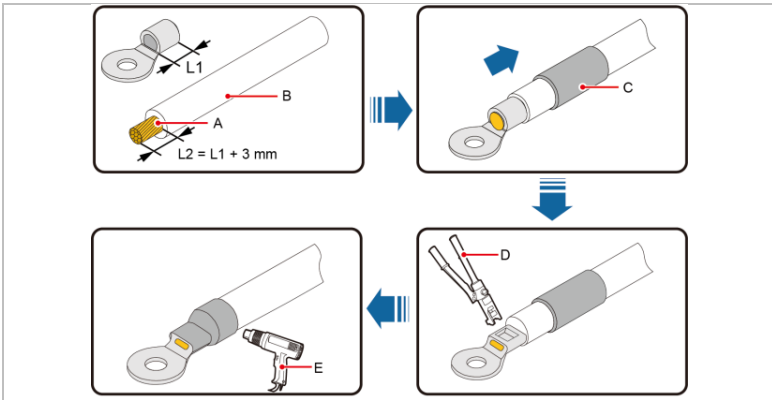

A Core wire

B Insulation layer

C Heat shrink tubing

D Hydraulic pliers

E Heat gun

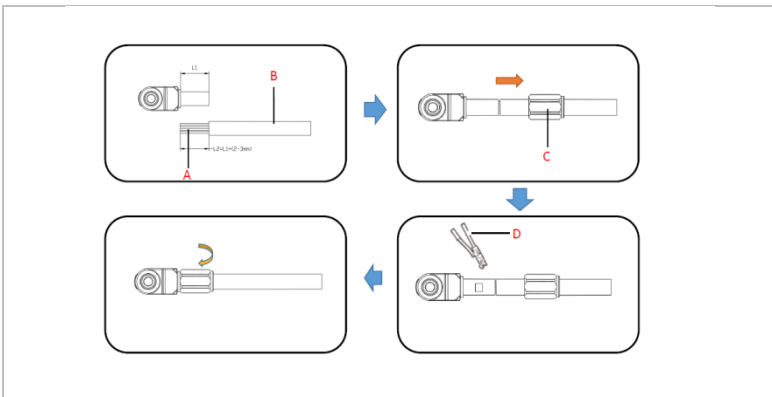













A Core wire

B Insulation layer

C Protective cover

D Hydraulic pliers

## 5.2 Tools

No.	Tool	Model	Function
01		Knife	Installation
02		Hammer drill Recommended drill diameter: 12 mm	Used to drill holes in the wall.
03		Socket wrench(10/16mm)	Installation
04		Rubber mallet	Installation
05		Cross screwdriver	Wiring
06		Inclinometer	Installation
07		Measuring tape	Used to measure distances
08		Diagonal pliers	Installation
09		Marker	Used for marking
10		ESD gloves	for the installer
11		Safety goggles	for the installer
12		Anti-dust respirator	for the installer
13		Safety shoes	For the installer

### 5.3 Installation requirements

#### 5.3.1 Installation environment Requirements

- ▶ Install the battery in the indoor environment.
- ▶ Place battery in secure location away from children and animals.
- ▶ Do not place the battery near any heat sources and avoid sparks.
- ▶ Do not expose the battery to liquids.
- ▶ Do not expose the battery to direct sunlight.

#### 5.3.2 Installation carrier requirements

- ▶ The mounting carrier shall have fire resistance. Do not install batteries on flammable buildings.
- ▶ The mounting carrier surface shall meet the load bearing requirements.



### 5.4 Installation instructions

#### 5.4.1 Dimensions

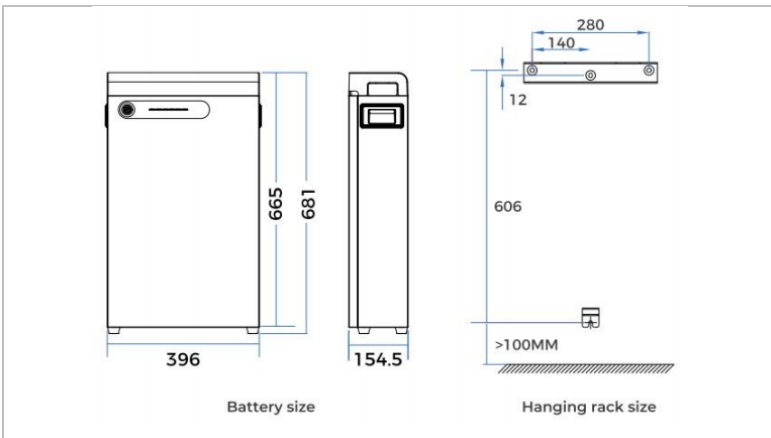

Minimum mounting distance between battery pack and other equipment:

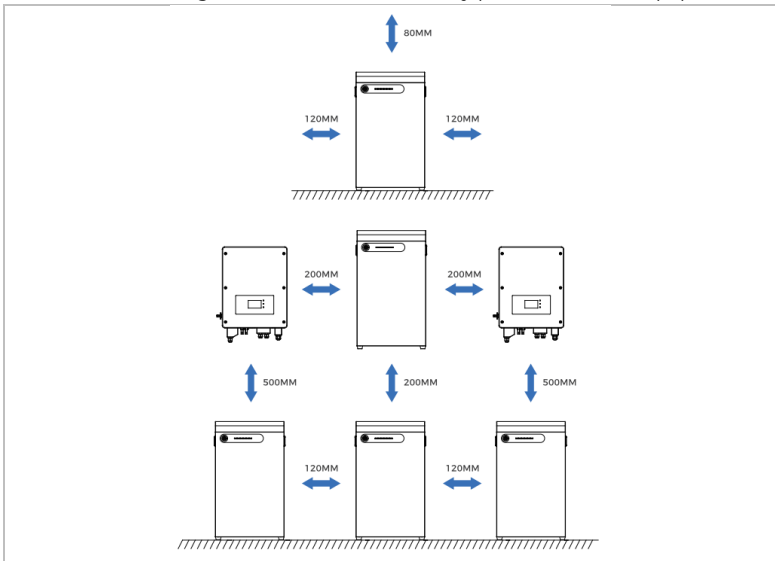

### 5.4.2 Installation Step

- ▶ Single Machine installation step for suspended on wall

#### Step 1

To determine the position for drilling holes, and then mark the hole position by using a marker, use the hammer drill to drill hole on the wall. Keeping the hammer perpendicular to the wall, do not shake when drilling, so as not to damage the walls. If the aperture errors, need to reposition.

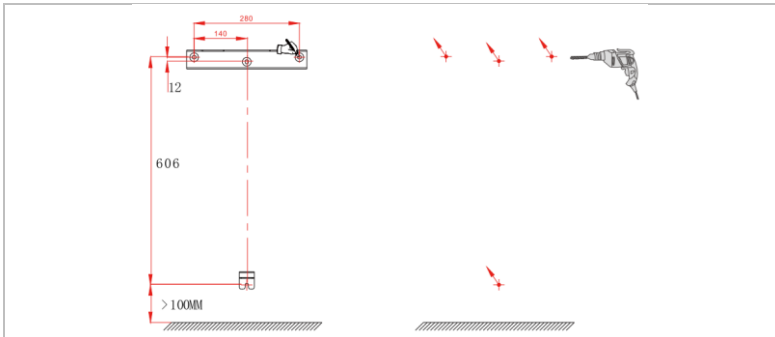

**Step 2**

Fix the wall Hanging rack 2 with expansion screws.

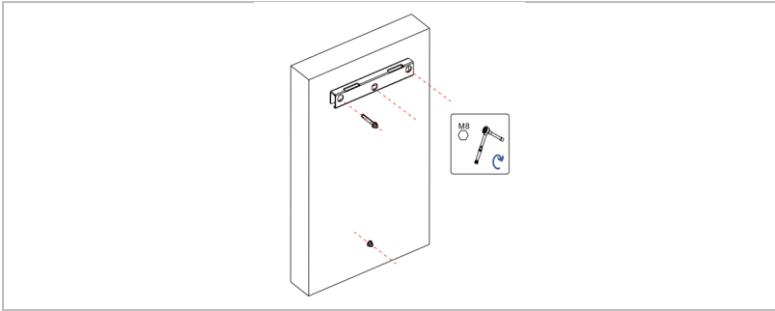

**Step 3**

Remove the battery and install the fixed leg.

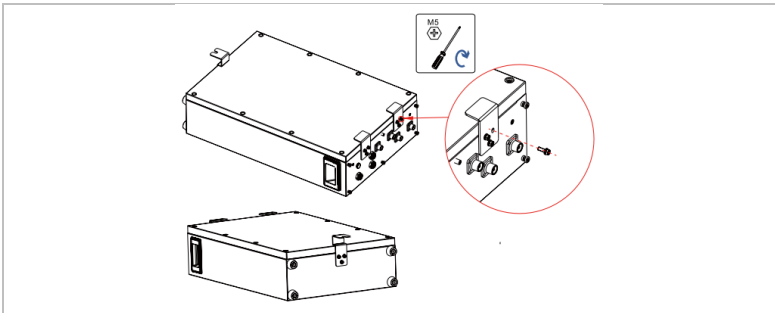

**Step 4**

Putting the battery hook on the hanging rack, fix the fixing screw to ensure the safety.

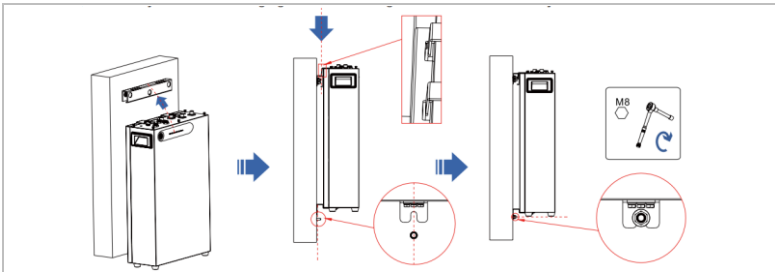

## 5.5 Electrical Connection

### 5.5.1 Electrical Connection Process

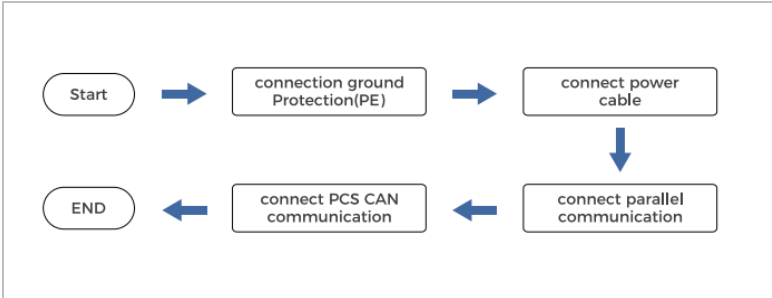

### 5.5.2 Wiring Step

#### Step 1

Connect PE line.

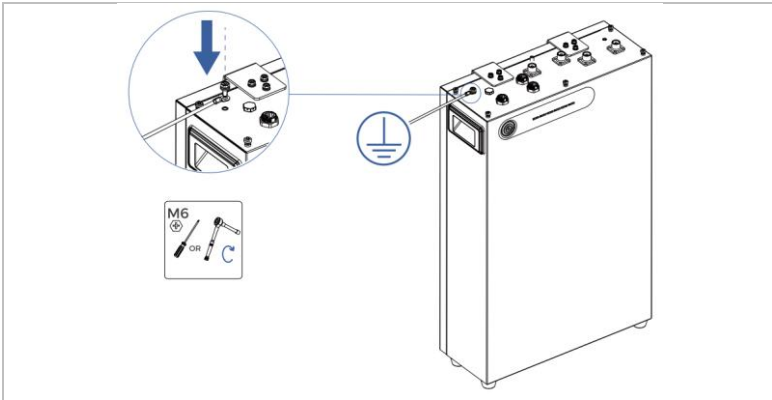

#### Step 2

Connect Power Cable from battery to isolation device.

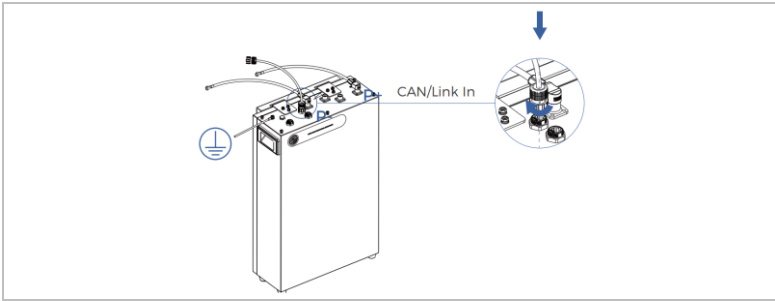

**Step 3**

Connect CAN/Link In communication line to PCS communication port.

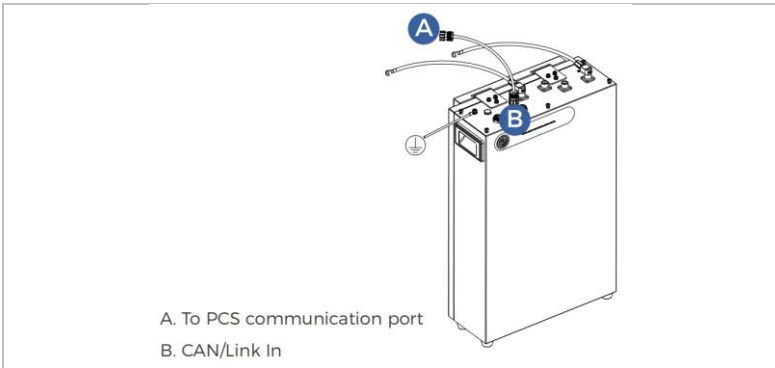

**Step 4**

Install the Decorative panel.

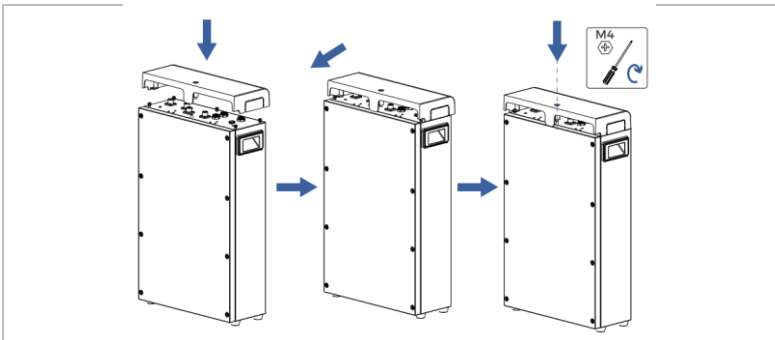

### 5.5.3 Parallel System Wiring Step

#### Step 1

Select a suitable location to install the battery system.

#### Step 2

Connect cables as follows.

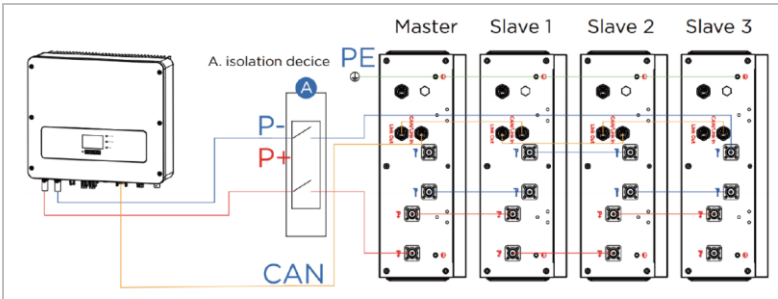

#### Step 3

Long press the start button of the Master PACK to start the battery system.

#### NOTE:

GTX5000S can be used in parallel with GTX5000PRO, but there are requirements for communication cables and wiring methods as follows:

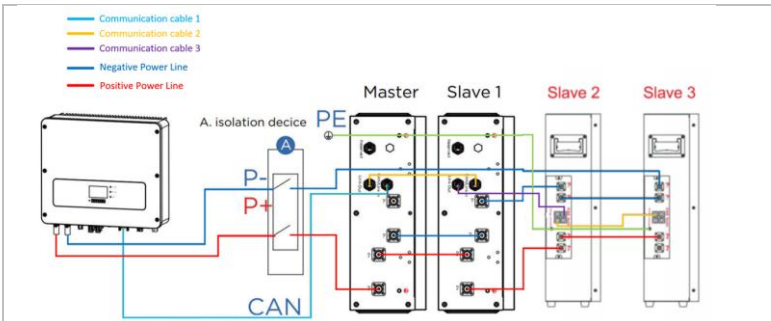

The specific requirements are set out below:

1. Communication cable 1 is the communication wire between the battery and the inverter, and a specific communication cable needs to be used based on the inverter model, refer to 4.3.1;
2. Communication cable 2 is a network cable with normal RJ45 connector (T568B wire order standard). And communication cable 3 is a special communication wire, material number 101060300211-0, both communication cables are used for parallel communication between batteries;
3. When mixing GTX5000S and GTX5000PRO, GTX5000S must be the host and all GTX5000PRO addresses need to be backward. When connecting the parallel communication cable between GTX5000S and GTX5000PRO, the "Link Out" port of GTX5000S is connected to the "CAN" port of GTX5000PRO.
4. When the battery is switched on, you need to switch on the GTX5000S first, and then the GTX5000PRO; when it is switched off, you need to switch off the GTX5000PRO first, and then the GTX5000S. You need to wait one minute after switching off to make sure that the battery is not switched on again before you can continue the operation.
5. When the GTX5000S is used in conjunction with the ME3000 inverter, or when the GTX5000S is used in parallel with the GTX5000PRO, the software version of the GTX5000S needs to be upgraded to V010062 or above.

## 6 Cleaning and Maintenance

### 6.1 Cleaning

 <b>CAUTION</b>
<p><b>Please power off the system before cleaning.</b></p> <ul style="list-style-type: none"> <li>▶ It is recommended that the SOFAR GTX5000S should be cleaned periodically. If the enclosure is dirty, please use a soft, dry brush or a dust collector to remove the dust. Liquids such as solvents, abrasives or corrosive liquids should not be used to clean the enclosure.</li> </ul>

### 6.2 Maintenance

#### 6.2.1 Recharge Requirements During Normal Storage

Batteries should be stored in an environment with a temperature range between  $-10^{\circ}\text{C} \sim +45^{\circ}\text{C}$ , and maintained regularly according to the following table with 0.5C (50A) current until 40% SOC after a long time of storage.

**Recharge conditions when in storage**

Ambient temperature( $^{\circ}\text{C}$ )	$T \leq -10$	$-10 < T \leq +45$	$T > +45$
Maximum storage time(months)	<b>Prohibited</b>	24	<b>Prohibited</b>

### 6.2.2 Recharge Requirements When Over Discharged

Please recharge the over discharged (90%DOD) batteries in a timeframe that is in accordance to the following table, otherwise the over discharged battery modules will be damaged.

**Recharge conditions when battery is over discharged**

Storage Environment Temperature	Storage Time	Note
-10~25°C	≤15 days	Battery Pack disconnect to PCS
25~45°C	≤7 days	
-10~45°C	< 12 hours	Battery Pack connect to PCS

### 6.2.3 Replacement or Expand capacity

The maintenance of batteries requires a person with professional skills.

1. Before replacement or expand capacity, please cut off the whole system, include PCS and Battery system; at the same time, PCS is disconnected from the power grid;
2. After PCS is confirmed to be disconnected from the power grid, turn off the battery power supply and disconnect the connection line between the battery and PCS.
3. Remove or install new battery refer to section 5. 5, and then restart refer to section 4. 2. 1.

## 6.2.4 Emergency

Please cut off the power supply and turn off the battery in an emergency.

### 1. Wet Batteries

If the battery pack is wet or submerged in water, do not let people access it, and then contact SOFAR or an authorized dealer for technical support.

### 2. Fire

NO WATER! Only dry powder fire extinguisher can be used; if possible, move the battery pack to a safe area before it catches fire.

### 3. Leaking Batteries

If the battery pack leaks electrolyte, avoid contact with the leaking liquid or gas. If someone is exposed to the leaked substance, immediately perform the actions described below.

Inhalation: Evacuate the contaminated area, and seek medical attention.

Contact with eyes: Rinse eyes with flowing water for 15 minutes, and seek medical attention.

Contact with skin: Wash the affected area thoroughly with soap and water, and seek medical attention.

Ingestion: Induce vomiting, and seek medical attention.

### 4. Damaged Batteries

Damaged batteries are dangerous and must be handled with the utmost care. They are not fit for use and may pose a danger to people or property. If the battery pack seems to be damaged, pack it in its original container, and then return it to SOFAR or an authorized dealer.

## 7 DataSheet

Model	GTX5000S
<b>System Parameters</b>	
Battery type	LFP
Total energy	5120Wh
Usable energy	4608Wh
Rated voltage	51.2V
Operating voltage range	44.8V~57.6V
Rated charging/discharging power	2560W
Rated charging/discharging current	50A
Max. charging/discharging current	50A
Max. Parallel Quantity	4pcs
<b>General Parameters</b>	
Communication	CAN
Dimension (W*H*D)	396*681*154.5mm
Weight	45kg
Protection rating	IP65
Cooling	Natural
Operating temperature	Charge: 0°C ~ +55°C / Discharge: -20°C ~ +60°C
Humidity	5%~95%
Installation	Wall Mounted / Floor Stand

Max. operating altitude	2000 m
<b>Standard</b>	
UN38. 3, IEC62619, IEC62040-1, SAA etc	



ENERGY TO POWER YOUR LIFE

**ADDRESS**

No.1, Dongsheng North Road, Chenjiang Street  
Zhongkai High-tech Zone, Huizhou City, China

**EMAIL**

[info@sofarsolar.com](mailto:info@sofarsolar.com)

**WEBSITE**

[www.sofarsolar.com](http://www.sofarsolar.com)

SOFARSOLAR 

